

Gas Purifier for CI/MS Applications

- 1/8" compression fittings
- 1000 psig pressure rating
- Compatible with most CI gases
- Welded stainless steel body



Description

The use of Chemical Ionization Mass Spectroscopy has increased in recent years, with instrumentation to perform this sensitive analytical technique now available commercially. In response to this growth, VICI Metronics has developed a gas purifier designed specifically for the unique demands of chemical ionization.

Several types of contaminants are detrimental to CI performance – notably moisture, heavy hydrocarbons, halocarbons, and oxygen. A Metronics CI purifier module placed in line with the gas delivery system removes these contaminants, reducing levels from many parts per million to levels that are below the lower limit of analytical detection, and retains them for the operating life of the purifier. (Recommended replacement is after three bottles of gas, or if detector baseline drift and noise become apparent.)

Successive Beds for Peak Performance

A very high capacity has been engineered into the gas purifier by using several different materials for gross contaminant removal and additional materials for the removal of trace amounts of the contaminants. Three separate adsorption chemistries are incorporated into the operating design of the gas purifier to insure the optimal capacity and efficiency. This successive bed format insures high capacity as well as a very high efficiency for the removal of contaminants that can be present in even high purity methane.

Our successive bed format achieves the highest purity gas commercially available

Two very high capacity hydrocarbon and moisture sorbents at the inlet for effective contaminant removal

Unique proprietary broad spectrum sorbent material for multiple contaminant removal

Multiple bed format to allow several step reduction in contaminants

Removal of H₂O, O₂, halocarbons, hydrocarbons, CO, CO₂, H₂, and sulfur containing compounds with a single purifier

Very high efficiency sorbents at the outlet for trace contaminant removal

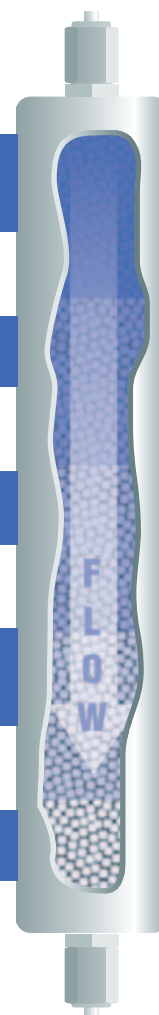

Fittings: the Fewer the Better

Every connection in your gas delivery system has the potential for leaks; the more fittings you have, the greater the potential. In the illustration below, several gas purification options are depicted:

- A** The VICI Metronics nitrogen purifier minimizes the number of fittings. Total: **2 fittings**
- B** The “Manifold System” has two compression fittings for the system and one organic O-ring seal for each cartridge. Total: **At least 5 fittings**
- C** A typical “Contaminant Trap” configuration has several components. Before the gas supply even enters the instrument, there are at least 4 modules. Total: **At least 8 fittings**

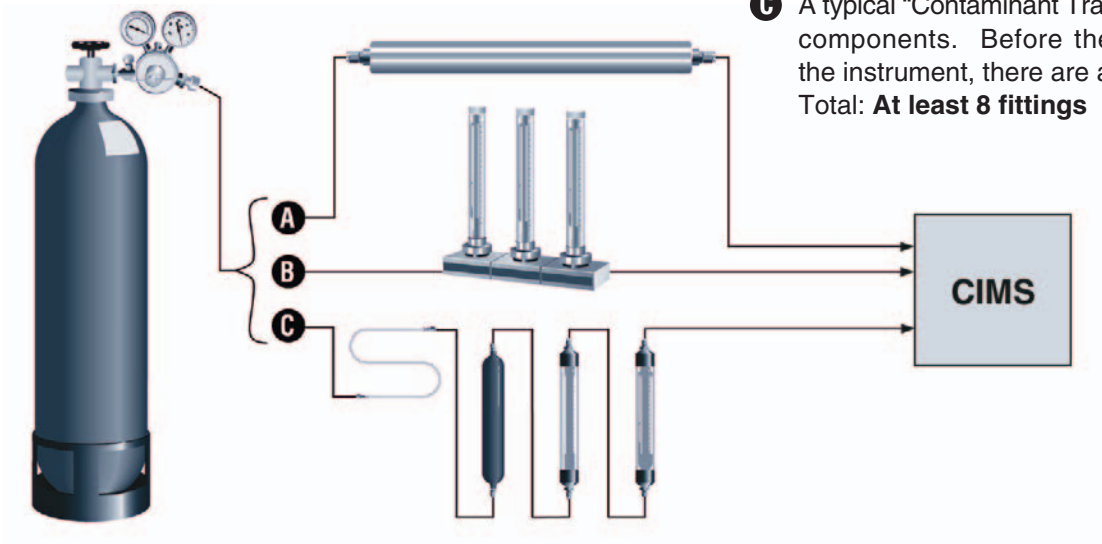

Specifications

Length	30.5 cm (12")	Pressure drop, 862 kPa (125 psi) inlet,
Diameter.....	3.8 cm (1.5")	at a flow of 0 to 500 ml/min
Maximum inlet pressure	6895 kPa (1000 psi)	<0.20 psi
Maximum recommended flow	500 ml/min	End fittings
		Shipping weight
		1/8" compression
		.800 g (1.76 lb)

Selection Guide and Ordering Information

Product Description	Product no.	Fitting	PPB at outlet, based on 50 PPM nominal inlet concentration level		
			O ₂	H ₂ O	Sulfur compounds
Cl purifier	P-500-1	1/8"	<1	<1	<1

VICI®Metronics
 tel: 360 697-9199
 fax: 360 697-6682
 purifiers@vici.com

VICI AG
VICI AG International
 tel: Int + 41 41 925-6200
 fax: Int + 41 41 925-6201
 info@vici.ch

**US customers
 call toll-free
 (877) 737-1887**